

**CUSTOM MADE**  
**SACE LIMITOR series**  
**RETROFIT solution**

**2023**



# WHY RETROFITTING?

Thanks to the wide range of its circuit breaker retrofit kits, C.M.G. Quadri allows customers to increase safety, ensure continuity of service and control the budget by reducing maintenance costs and avoiding expensive spare parts.







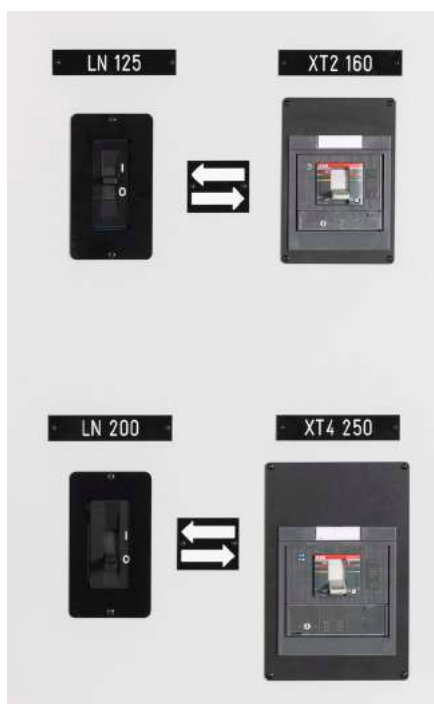

Our retrofit solutions allow clients to benefit from modern Moulded Case Circuit-Breakers which ensure high mechanical and electrical reliability and great flexibility, thanks to new high-technology electronic protections.



**“C.M.G. Quadri offers tailor made circuit breaker retrofit solutions to suit customers’ needs.”**



# HOW TO QUICKLY IMPROVE YOUR FLEET EFFICIENCY?

- |   |  |   |   |
|---|--|---|---|
|  | LOW cost for maintenance and repairing |  | HIGH cost for maintenance and repairing |
|  | LOW spare parts costs                  |  | HIGH spare parts costs                  |
|  | NEW technology                         |  | OLD technology                          |
|  | STATE-OF-THE-ART circuit breaker       |  | OBSOLETE circuit breaker                |

## CIRCUIT BREAKER AND RETROFIT CERTIFICATE

Circuit Breakers are tested by the manufacturer according to the standard IEC 60947-2 about “Low-voltage switchgear and controlgear – Part 2: Circuit-breakers”.

Retrofit kits are made according to the standard IEC 61439-2 about “Low voltage switchgear and controlgear assembly”.



# LATEST STUDY REFERENCES

## SILVER WIND (LUXURY CRUISE SHIP)

WHERE: LISBON - MONTE CARLO

WHEN: MAY 2015

WHAT: VARIOUS RETROFIT SOLUTIONS



## EUROCARGO NAPOLI (PASSENGER SHIP)

WHERE: NAPOLI

WHEN: MAY 2018

WHAT: RETROFIT SOLUTION FOR DA



## COSTA NEOROMANTICA (CRUISE SHIP)

WHERE: SHANGAI

WHEN: DECEMBER 2017

WHAT: RETROFIT SOLUTION FOR LN125, LN 200, LN 320



## SAIPEM 10000 (ULTRA DEEPWATER DRILLSHIP)

WHERE: MAIORCA

WHEN: MAY 2015

WHAT: VARIOUS RETROFIT SOLUTIONS



## MY AMBROSIA (MEGA YACHT)

WHERE: TAIWAN

WHEN: DECEMBER 2017

WHAT: RETROFIT SOLUTION FOR S6X



## PUENTE NUEVO POWER PLANT

WHERE: PUENTE NUEVO (SPAIN)

WHEN: FEBRUARY 2012

WHAT: VARIOUS RETROFIT SOLUTIONS



## AREAS OF INTERVENTION

Marine, Industrial plants, Energy generation & distribution, Oil & Gas, Petrochemical.

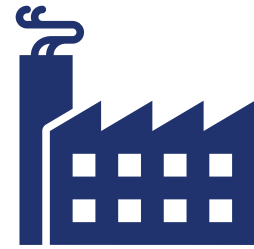

## OPERATIVE WORLDWIDE

We are used to make intervention either in dry-dock or in navigation.



## SHORT OUT OF SERVICE OF YOUR SYSTEMS

Installation time (one circuit-breaker): 30-60 mins.



## QUICK ASSISTANCE

We answer within 1 working day.





# SACE LIMITOR series

## RETROFIT solution

To answer all customers demands for the **LIMITOR RETROFITTING**, C.M.G. Quadri developed PLUG AND PLAY retrofit kits: the obsolete circuit-breaker is completely removed and replaced by the new circuit-breaker. The kit contains busbars, covers and supports designed to adapt the new circuit-breaker to the existing busbars.

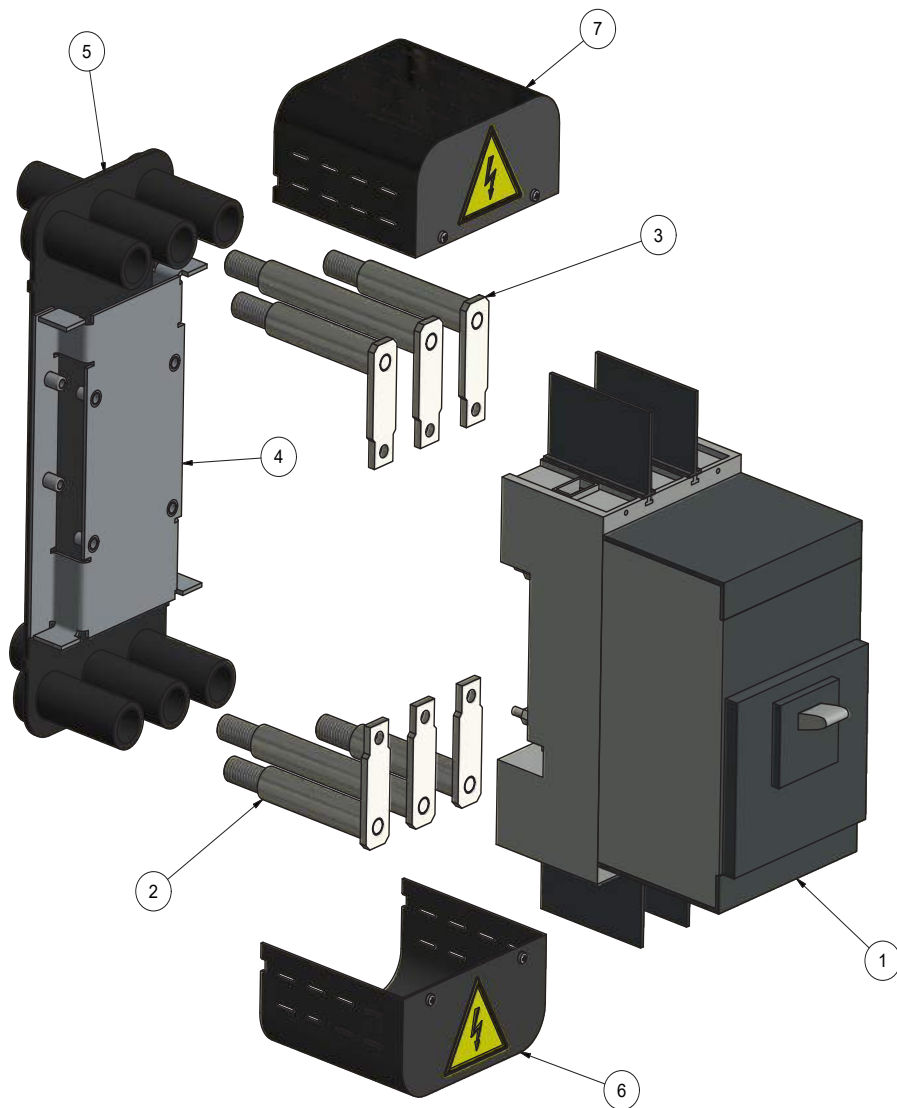

7	UPPER COVER
6	LOWER COVER
5	INSULATION BASE
4	SUPPORT
3	UPPER CONNECTION ADAPTATION
2	LOWER CONNECTION ADAPTATION
1	NEW CIRCUIT BREAKER
POS.	DESCRIPTION

The kits are constantly updated and may slightly differ from the picture above



# DO IT!

## “KIT ONLY” SOLUTION

- We send you only the retrofit kit. You have to buy the new circuit breaker and You have to install it. We help you in the choice of the exact circuit-breaker model that you have to buy and we include the installation manual for the kit.

## “KIT & CIRCUIT BREAKER” SOLUTION

- We send you both the retrofit kit and the circuit breaker. You have to install it: we include the installation manual.

## “FULL SERVICE” SOLUTION

- We send you the retrofit and the new circuit breaker. We install and test it everywhere around the world.

**SHIPMENT AND  
INSTALLATION  
WORLDWIDE**



## LIMITOR LN 100/125



EXISTING CIRCUIT BREAKER	OLD VERSION	NEW CIRCUIT-BREAKER (ABB)	NEW VERSION	Icu @ 440V 50-60Hz (AC)	RETROFIT SOLUTION CODE (3P)	RETROFIT SOLUTION CODE (4P)
LIMITOR LN 100	P - FT	XT2 L 160	P - EF EF	100 KA ->	3286M100	3286M102
LIMITOR LN 100	P - RT	XT2 L 160	P - EF EF	100 KA ->	2846M102	3286M104
LIMITOR LN 125	P - FT	XT2 L 160	P - EF EF	100 KA ->	3286M100	3286M102
LIMITOR LN 125	P - RT	XT2 L 160	P - EF EF	100 KA ->	2846M102	3286M104

\* P= PLUG-IN \* W=WITHDRAWABLE \*\*FT= FRONT TERMINAL \*\*RT=REAR TERMINAL \*\*EF= FRONT EXTENDED TERMINAL

## LIMITOR LN 160/200



EXISTING CIRCUIT BREAKER	OLD VERSION	NEW CIRCUIT-BREAKER (ABB)	NEW VERSION	Icu @ 440V 50-60Hz (AC)	RETROFIT SOLUTION CODE (3P)
LIMITOR LN 160	P - FT	XT4 L 250	P - EF EF	100 KA ->	2893M100
LIMITOR LN 160	P - RT	XT4 L 250	P - EF EF	100 KA ->	2893M102
LIMITOR LN 160	W - FT	XT4 L 250	W - EF EF	100 KA ->	3287M100
LIMITOR LN 160	W - RT	XT4 L 250	W - EF EF	100 KA ->	3287M102
LIMITOR LN 200	P - FT	XT4 L 250	P - EF EF	100 KA ->	2893M100
LIMITOR LN 200	P - RT	XT4 L 250	P - EF EF	100 KA ->	2893M102
LIMITOR LN 200	W - FT	XT4 L 250	W - EF EF	100 KA ->	3287M100
LIMITOR LN 200	W - RT	XT4 L 250	W - EF EF	100 KA ->	3287M102

\* P= PLUG-IN \* W=WITHDRAWABLE \*\*FT= FRONT TERMINAL \*\*RT=REAR TERMINAL \*\*EF= FRONT EXTENDED TERMINAL



# LIMITOR LN 320



EXISTING CIRCUIT BREAKER	OLD VERSION	NEW CIRCUIT-BREAKER (ABB)	NEW VERSION	Icu @ 440V 50-60Hz (AC)	RETROFIT SOLUTION CODE (3P)
LIMITOR LN 320	P - FT	T4 L 320	P - EF EF	100 KA	-> 3288M100
LIMITOR LN 320	P - RT	T4 L 320	P - EF EF	100 KA	-> 2703M100
LIMITOR LN 320	W - FT	T4 L 320	W - EF EF	100 KA	-> 3288M102
LIMITOR LN 320	W - RT	T4 L 320	W - EF EF	100 KA	-> 3288M104

\* P= PLUG-IN \* W=WITHDRAWABLE \*\*FT= FRONT TERMINAL \*\*RT=REAR TERMINAL \*\*EF= FRONT EXTENDED TERMINAL

# LIMITOR LN 500



EXISTING CIRCUIT BREAKER	OLD VERSION	NEW CIRCUIT-BREAKER (ABB)	NEW VERSION	Icu @ 440V 50-60Hz (AC)	RETROFIT SOLUTION CODE (3P)	RETROFIT SOLUTION CODE (4P)
LIMITOR LN 500	P - FT	T5 L 630	P - EF EF	100 KA	-> 3289M100	2677M108
LIMITOR LN 500	P - RT	T5 L 630	P - EF EF	100 KA	-> 2677M104	2677M100
LIMITOR LN 500	W - FT	T5 L 630	W - EF EF	100 KA	-> 3289M102	2677M110
LIMITOR LN 500	W - RT	T5 L 630	W - EF EF	100 KA	-> 2677M106	2677M102

\* P= PLUG-IN \* W=WITHDRAWABLE \*\*FT= FRONT TERMINAL \*\*RT=REAR TERMINAL \*\*EF= FRONT EXTENDED TERMINAL

# HOW TO START?

1

Identify the existing LIMITOR  
CIRCUIT BREAKER

2

Contact us and we will guide You through the choice of the correct  
RETROFIT SOLUTION CODE

3

Choose among "KIT ONLY" or "KIT&CIRCUIT BREAKER"  
or "FULL SERVICE" solutions

4

You will get a price quotation and all  
information you need

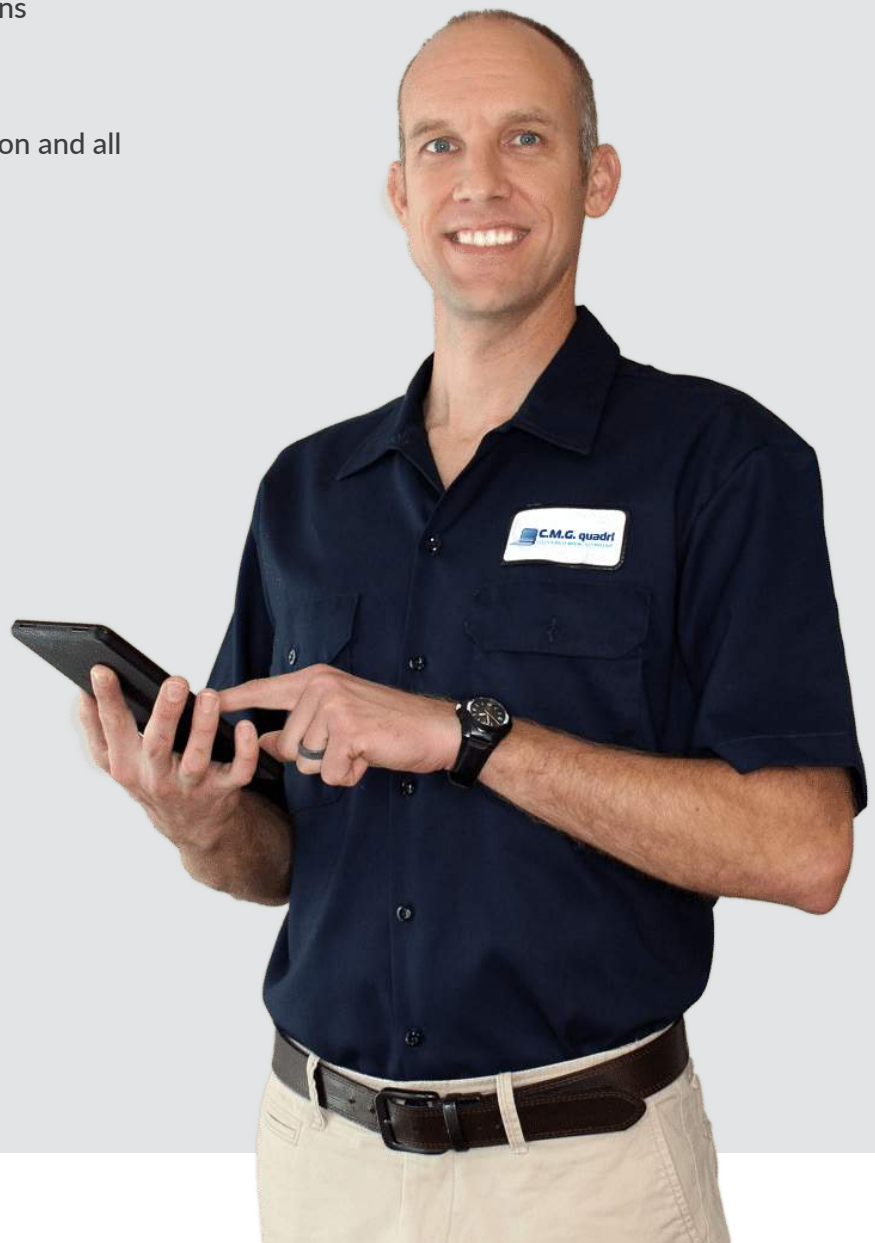

# C.M.G. QUADRI

CMG QUADRI is an Italian Company with 25 years experience within MV-LV electrical system repair in marine and industrial fields worldwide.

We have developed over the years our specialization on revamping & repowering of switchgears, modernization of control and protection systems and retrofit of existing MV-LV circuit breakers - open or moulded case - of the world's leading brands.

Contact us today to discuss your bespoke project or ask for more information.

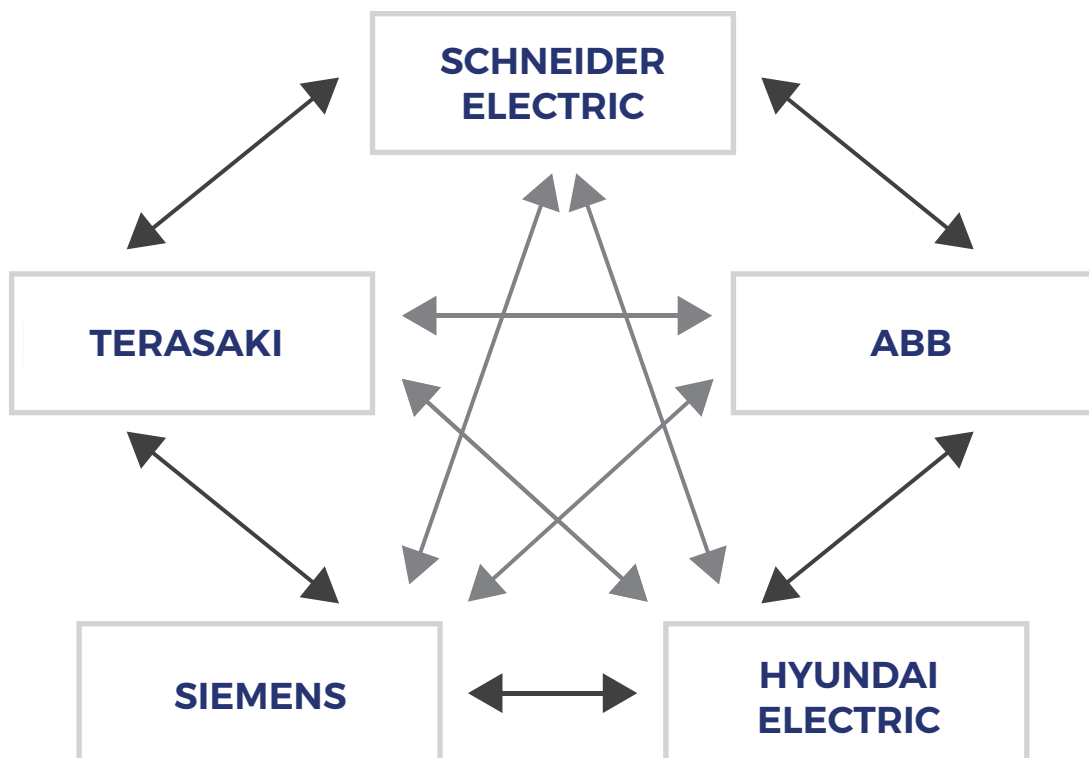

DEMONSTRATIVE PICTURES FROM VARIOUS BRANDS



**CUSTOM MADE**  
**SACE LIMITOR series**  
**RETROFIT solution**

---

 Via Boschetti, 65 - 24050 Grassobbio (BG), Italy

 +39 035 526748

 [info@cmgquadri.it](mailto:info@cmgquadri.it)

 <http://www.cmgquadri.it/>